

WWW.TAISHAN.WS

TITLE: 二次加温双压吸塑机系统接线图		REV: 1.2
TAISHAN	Company: TAISHAN	Sheet: 1/2
	Date: 2020-06-12	Drawn By: peter_zhly

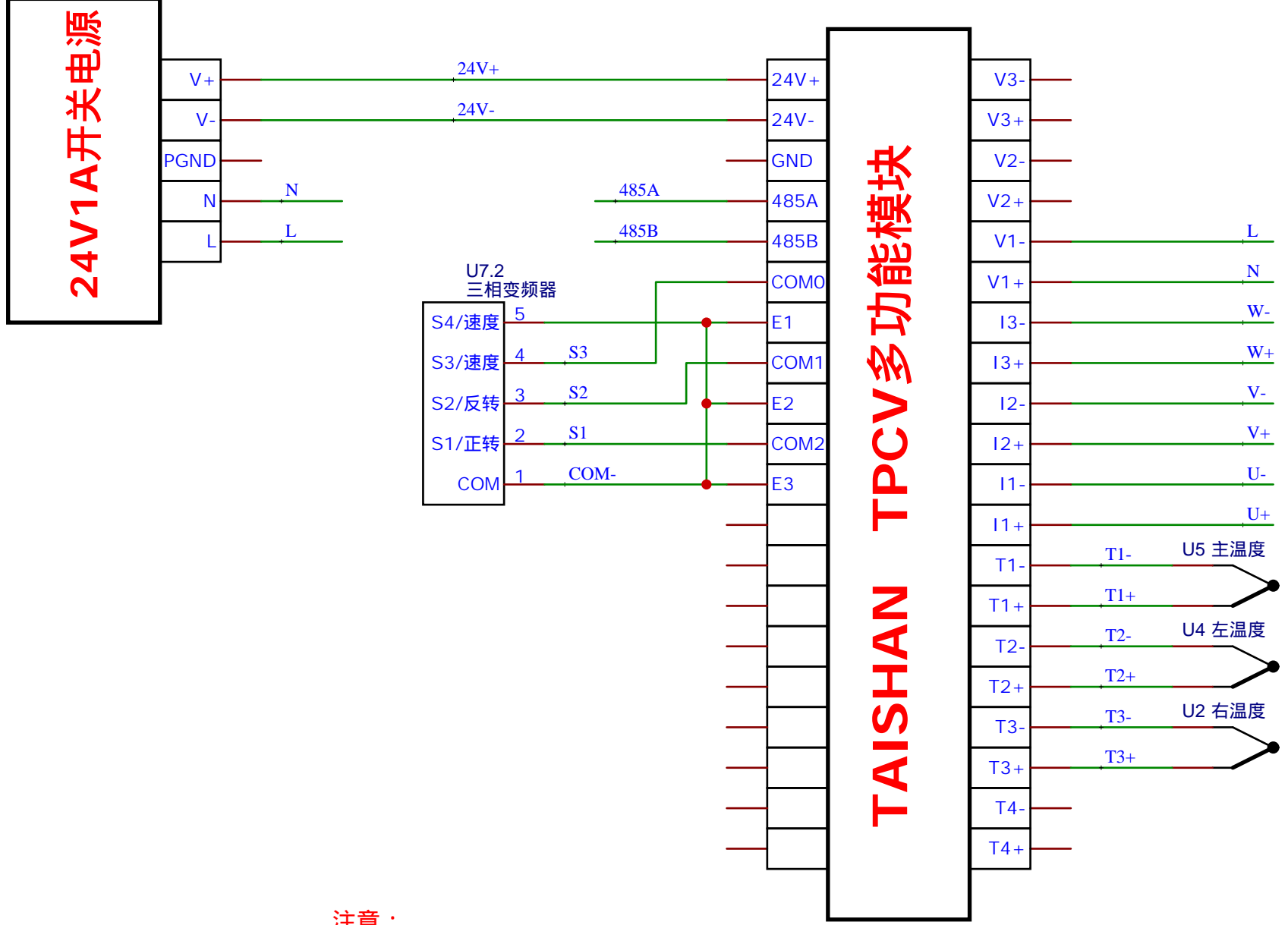
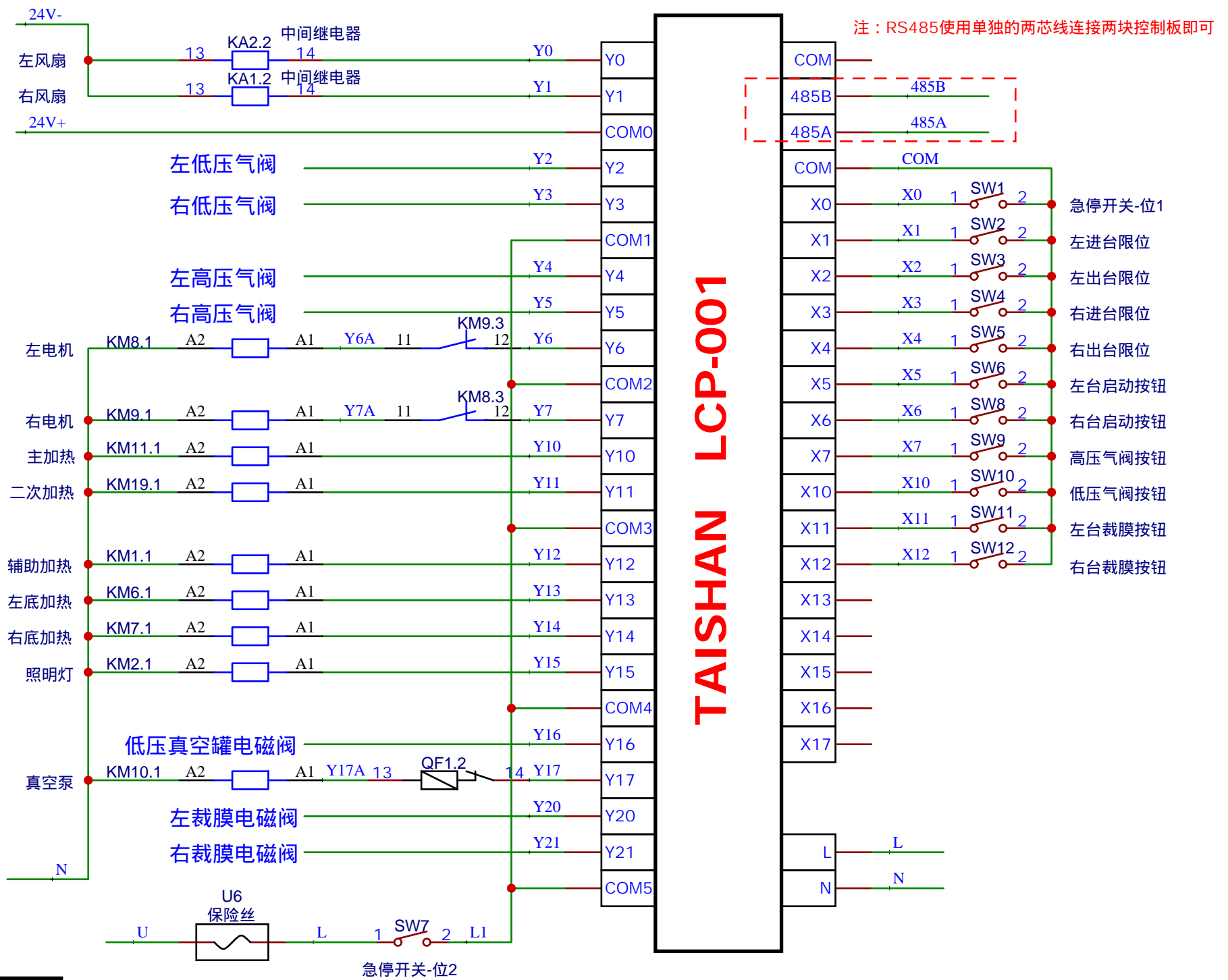

注意：
真空电磁阀、裁膜电磁阀直接由系统驱动，一端接输出端，一端接零线即可

WWW.TAISHAN.WS

TITLE: 二次加温双压吸塑机系统接线图		REV: 1.2
TAISHAN	Company: TAISHAN	Sheet: 2/2
	Date: 2020-06-12	Drawn By: peter_zhly